

PART 1 AIRWORTHINESS 'AGGRO' (GLIDERS).

Please add these items to the 1977 list of Mandatory Mods and Inspections.

1.1 DG100 and DG100b.

TN 301-4-2 (attached) requires inspection of aileron controls in the cockpit for foul between guide plate and undercarriage control. Inspection to be carried out as soon as possible.

1.2 JANTAR (Series)

Lower rudder hinge failure at the base of the pintle. The wooden support structure has failed, probably due to overload applied to the rudder when manoeuvring into/out of trailers. Inspection is possible through detachable panel. 'No Handling' should be stencilled on rudder. Reported by P. Whatford, Dunstable.

1.3 JANTAR

Undercarriage mechanism failures.

a) Lock failure due to rotation of the wheel locking shaft. Ref sketch by Tim Macfadyen.

b) Lock failure due to wear etc on locking plunger - Ref sketch by R. Blackmore.

1.4 JANTAR

Flap operating lever fractures. Attached sketch by P. Davis (Lasham) gives details of fracture/repair of pilot's flap operating lever.

1.5 PIRAT

Rudder cables found in poor condition after only 260 flying hours. Replaced by American type cables of improved quality. (P. R. Johnson).

1.6 T.49 CAPSTAN

Rudder Pedal Stops - Bent, allowing rudder to lock-over. Ref sketch from Len Morris (Swindon G.C.)

1.7 VTC Open Cirrus

Failure of air brake quadrant pivot. Tack weld failure of stud as indicated in sketch by J. S. Riddock - N.Weald.

PART 2 AIRWORTHINESS 'AGGRO' - POWERED AIRCRAFT

2.1 MS 893 E Rallye Commodore

Nose-wheel shimmy caused separation of the nose-wheel assembly from the aircraft and failure of the axle. Secondary damage inflicted to tailplane/Elevator. (Ref G.A.S.I. 3/77).

2.2 MS880B Rallye Club. (Ref G.A.S.I. 3/77)

Severe corrosion in fuselage and fin structure.

2.3 MS 880 B Rallye Club (Ref G.A.S.I. 4/77)

Spinner failure in-flight. Daily inspections should include examination of spinner and backplate assembly.

2.4 PA18-150 Super Cub.

Malfunction of the Rotary Ignition Switch type AAF-A7 resulted in serious injury to propeller swinger. (Ref G.A.S.I. 3/77).

B.G.A. Note: This switch is fitted to other types, and should be replaced, or frequently checked at Idle RPM for correct operation.

2.5 Piper Cub series - Fuel Tank Cap Vents.

F.A.A. A/D 77-09-09 effective 12th May, 1977, requires further checks that correct vent holes are drilled in Cap Part No 15296-02, which were made available in June, 1976.

PART 3 GENERAL MATTERS

3.1 Radio Station Approval.

Ref A-24-3-77 has been issued to Sharp Electronics VHF air band receiver type FX-209 AU.

3.2 'Parafil' launching ropes.

Two letters from P.C.M. of interest to clubs, are attached herewith, and cover cable strength, operating techniques and methods of repair.

3.3 Synthetic and Enamel Paints on synthetic fabrics (Geconite).

Dave Paton of Chiltern Sailplanes, Booker (0494 445854) has advice from paint manufacturers on applying a sealant to batyrate dopes to improve adhesion of paints.

3.4 Blanik L.13 'Safe-Life'

Telex received 13.5.77 from Ompipol, via U.K. Agents, Peter Clifford Aviation Ltd. Oxford Airport, Kidlington, Oxon (08675 - 4262), indicates that the manufacturer will have completed a review of Bulletin L13/042 by end of June 1977. B.G.A. will circulate results of these deliberations.

B.G.A. SHOP WINDOW AND PRICE LIST

1) Clinometers	£2.65	(incl. of postage)
2) Standard repairs to gliders	£2.25	"
3) 52 C.A.I.P. Leaflets	£5.20	"
4) BGA Winch & Auto-tow equipment.	60p	"
5) C of A renewal fee (gliders)	£8.64	
6) BGA Inspector renewal fee (October)	£6.00	
7) Motor-glider renewal fee	£15.00	

OXYGEN EQUIPMENT

Medical oxygen equipment is available from Air Apparatus and Valve Limited, Oakfield Works, Branksome Hill Road, College Town, Camberley, Surrey. (Mr. W. Fisher) - Camberley 35073.

R. B. STRATTON.
CHIEF TECHNICAL OFFICER.

* * * * *

Subject: Aileron control in the cockpit

Effectivity: DG-100 and DG-100 G W.-Nr. 42 - 83

Accomplishment: Before the next flight

Reason: If the guide plate of the under carriage control push rod is not filed out enough, the stop support of the aileron control push rod may butt against it.
 (Pushrod turned upwards to the most unfavorable position, see figure)
 This might happen during flight conditions under negativ -g- loads.

- Instructions:**
1. Remove the left side covering in the cockpit.
 2. Turn the aileron control pushrod upwards (see figure) and check the stop support for butting against the guide plate.

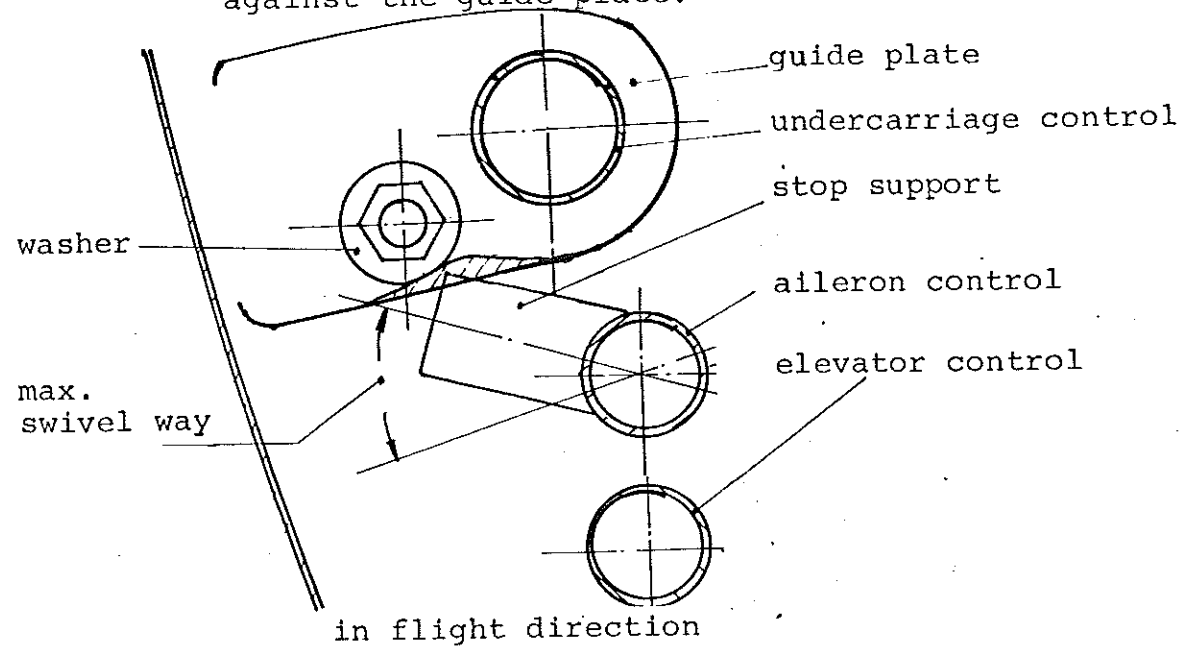

3. If the stop support push^s against the hatched region of the guide plate, file out this region. If necessary change the installed washer (outside diameter 18 mm) against one with outside diameter 12 mm. (6,4 DIN 125).
4. clean the area of filings
5. reinstall the side covering
6. Book the executed work in your log book.

Material: washer 6,4 DIN 125 if necessary

Weight and

Balance: no effect

Remarks: This work can be done by an experienced person.

Bruchsal 4, March 10th 1977

ADDITIONAL "L" BRACKET TO PREVENT THE WHEEL LOCKING

STANDARD JANTAR

TUBE ROTATING

The Bracket is mounted hard up against a flat on the locking tube end.

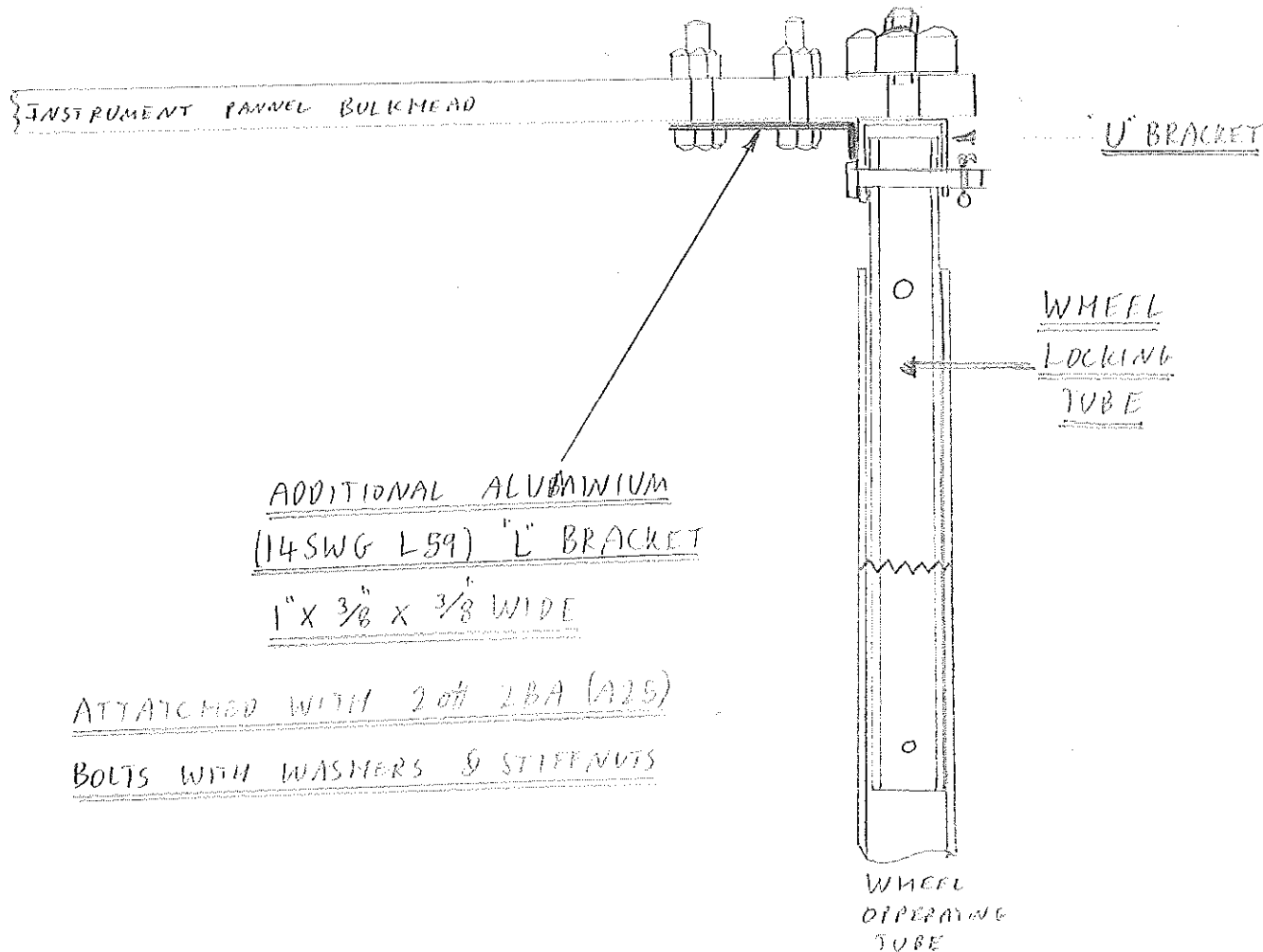

ATTACHED WITH 20# LBA (A25)
BOLTS WITH WASHERS & STIFFNUTS

A neater engineering solution would be to weld a $\frac{3}{4}$ " x $\frac{3}{8}$ " x 16 SWG
steel strip to the "U" bracket that is pinned to the locking tube end
and bolt this to the bulkhead.

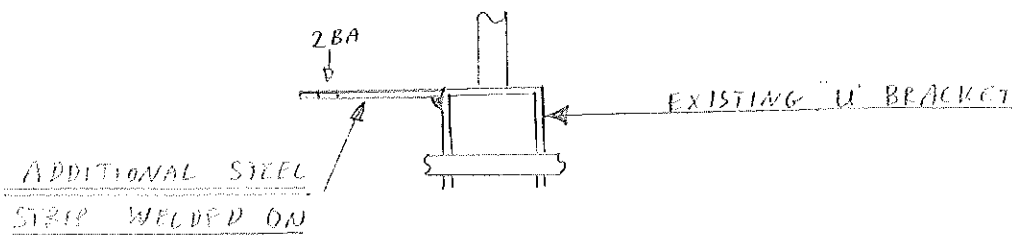

JANTAR/TNS/5/6/77

[Signature]

T.E. Muralidharan 16/3/77

JANTAR

STANDARD JANTAR

PART SECTION OF UNDERCARRIAGE

RETRACTION HANDLE

Latch 'B'

SHOWN IN LOCKED DOWN

POSITION

SCALE:- APPROX 1/4

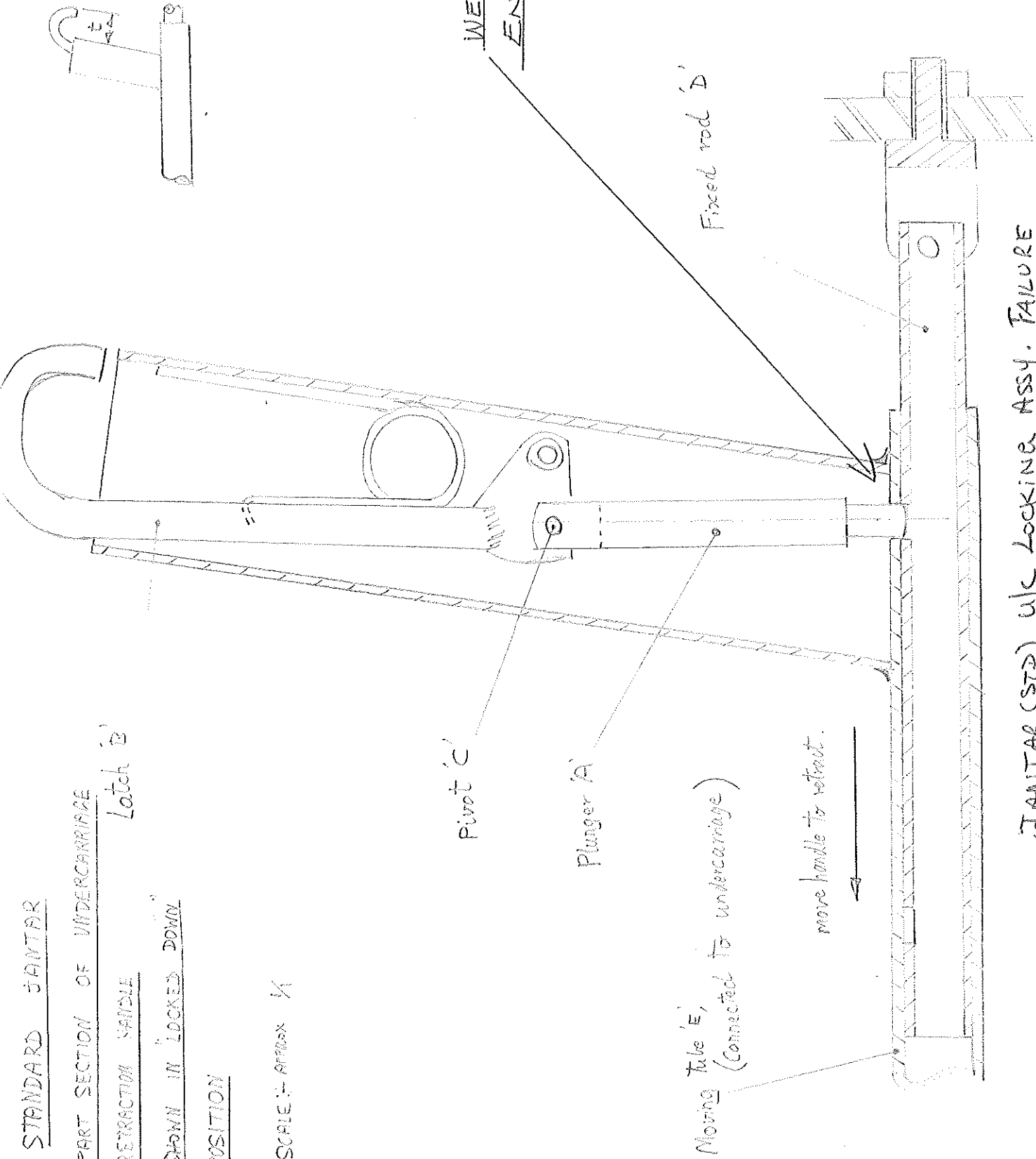

Fig. 'a'

Latch shown in fully withdrawn position

WEAR & LACK OF ENGAGEMENT

Fixed rod 'D'

Pivot 'C'

Plunger 'A'

Moving Tube 'E',
(Connected to undercarriage)

move handle to retract.

JANTAR (STD) U/C LOCKING ASSY. FAILURE TO LOCK.

Pilot's Control Lever.

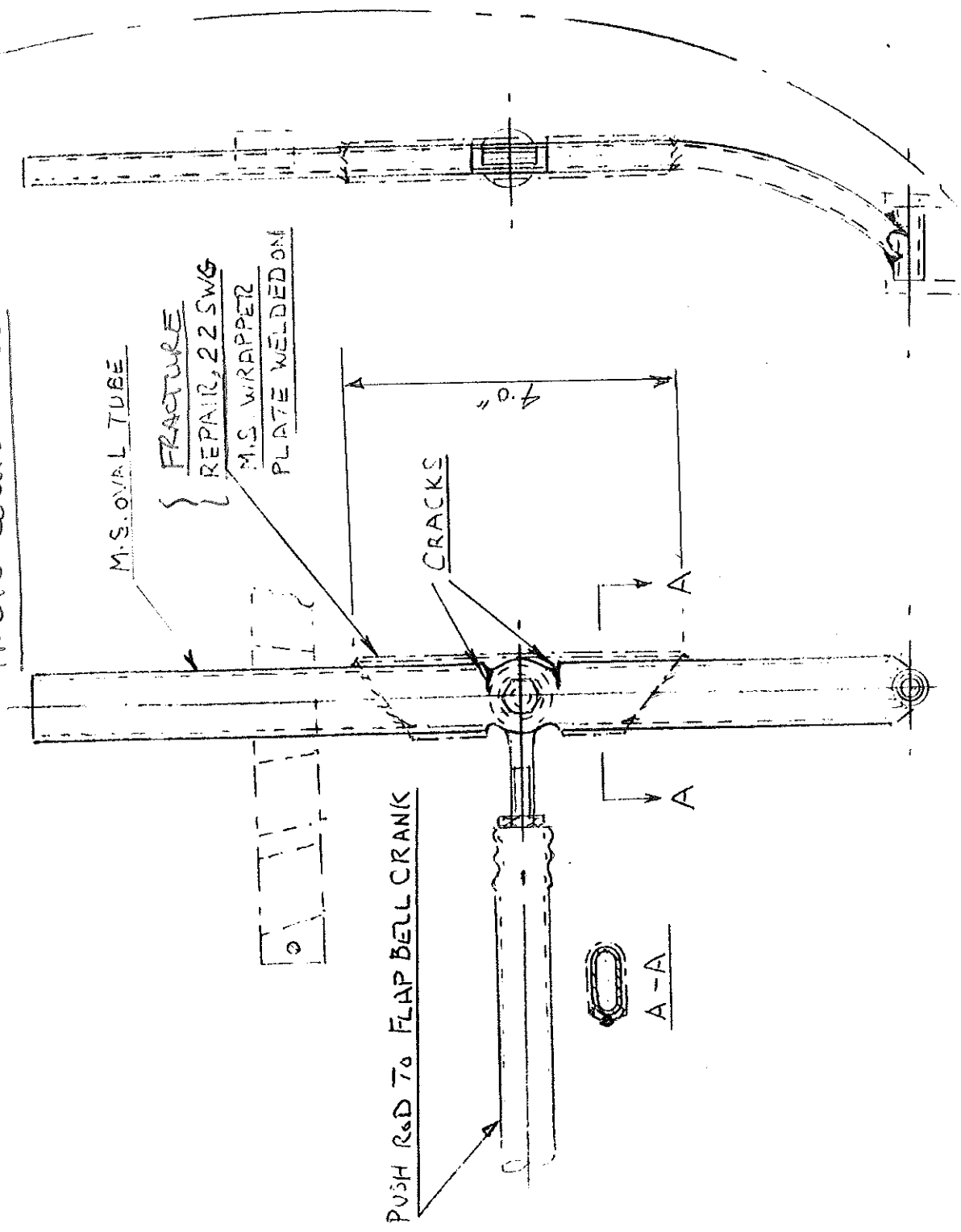

M.S. OVAL TUBE

FRACTURE

REPAIR, 22 SWG

M.S. WRAPPER

PLATE WELDED ON

PUSH ROD TO FLAP BELL CRANK

CRACKS

7.0"

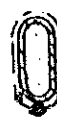

A-A

JANTAR I (SZD 38A) FLAP OPERATING LEVER

FAILURE/REPAIR

(NET TO SCALE)

JANTAR.

PD. 26-4-77

FLAPS

DAMAGED
Rudder Stop

T.49 Capstan Rudder Pedal Stop

AIRCRAFT

FRONT
FUSELAGE
PART SIDE
LOOKING
FORWARD

LOCKNUT
BEHIND

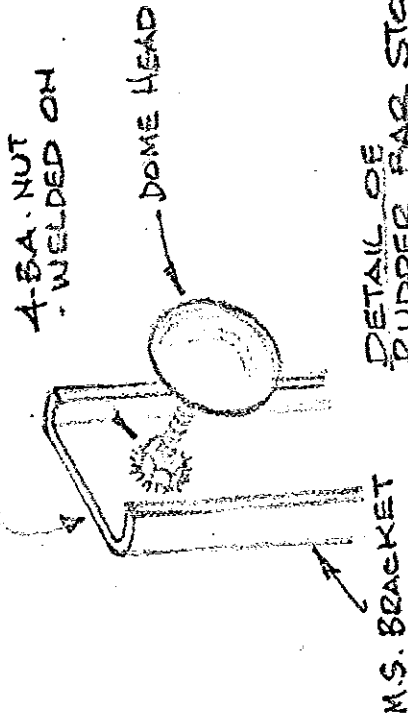

DETAIL OF
RUDDER BAR STOPS

RUDDER BAR
STOP BENT

RUDDER
BAR WEDGED
UNDER STOP

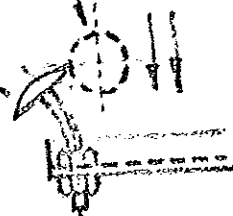

FRAME

LONGERON

RUDDER BAR
STOP BRACKET

RUDDER BAR STOPS
ON T.49 AIRCRAFT.

T.49 Capstan.

SWINDON GLIDING CLUB LTD
50 WITHMERE TOLL, SWINDON

16/4/77

Cirrus F
INS 5/6/77

OPEN CIRRUS VTC.
AIR BRAKE QUADRANT.

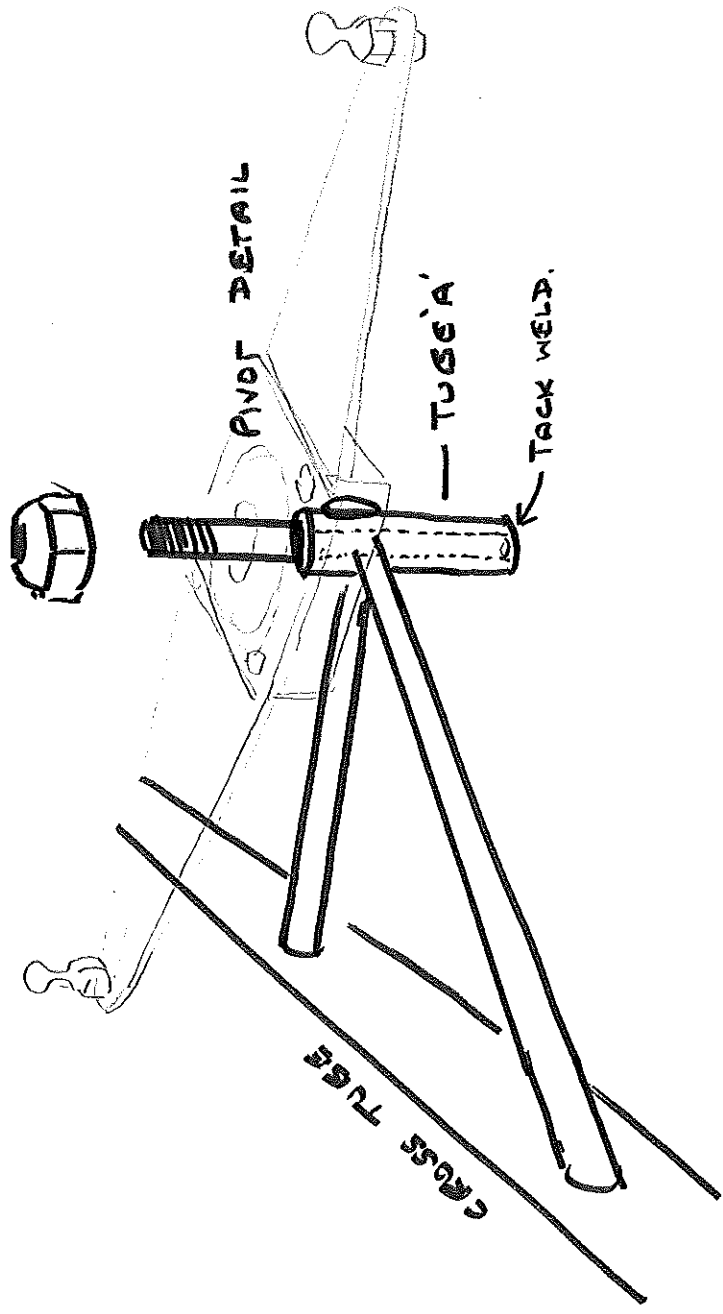

- 1/ Quadrant found loose, in up/down plane.
- 2/ Checked nut (self locking), then the stud became free in tube A.
- 3/ Dipped stud out, & find tack weld was once securing stud, as side fixing through tube A was NBS.
- 4/ Cleaned out tube A and inserted bolt as temporary measure.
- 5/ Stud inserted, as can be seen it is bent?
- 6/ Any admin please! - yes - FIXIT! Rhv

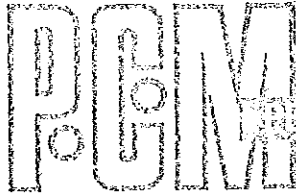

PARAFIL LAUNCHING ROPE TMS 5/6/77

THE BRITISH GLIDING ASSOCIATION MANUFACTURERS OF PARAFIL ROPE (SHEATHED)

Manufacturers Engineers

Manufacturers D.G.I., A.R.B. and I.N.O. Main Contractors

19-21 Kents Hill Road · Benfleet · Essex · SS7 5PN

Telephone · South Benfleet (03-745) 52711/2

Our Ref

TKP/MH

Your Ref

Date 22.4.77

R.B. Stratton, Esq.,
Chief Technical Officer,
British Gliding Association,
Kimberley House,
Vaughan Way,
Leicester.

PARAFIL LAUNCHING ROPE

Dear Sir,

We thank you for your letter of the 31st March, enquiring about the suitability of Parafil Rope for Glider Launching. I apologise for the delay in replying but I have been away for the past ten days on a business trip. As requested we are pleased to provide the following information concerning the use of Parafil for Winch Launching of Gliders. Experiments have been carried out on this subject by two Gliding Clubs namely RAF Swanton Morley, Norfolk and Kestrel RAF Odiham and you may get further information from them.

Parafil Rope Types

Type A - This is the standard I.C.I. product which is used for the majority of commercial/industrial applications. It comprises a terylene yarn core protected by an Alkathene sheath and has been found to be generally too stiff and not sufficiently hard wearing for Glider use. It is the cheapest rope in the Parafil range.

Type C - This is the preferred rope for Glider Launching applications. This also has a terylene yarn core but the sheath is made from E.V.A. (Ethylene/Vinyl Acetate). This sheath is more flexible than the Type A and has much better abrasion and cut resistance. Type C ropes are generally 20% more expensive than equivalent breaking load Type A.

Type F - This is a recent addition to the range using Kevlar yarn as the core material. It can be supplied with either an Alkathene or E.V.A. sheath. Kevlar is approximately three times the strength of terylene and therefore enables much higher strength ropes to be manufactured for a given cross section area. However there is not a size in the F Type range suitable for Glider Launching. Furthermore, Type F rope is approximately twice as dear as Type C and there is also some doubts as to its ability to withstand repeated flexing (i.e. over pulleys) because of breakdown of the core yarn through inter fibre friction.



Size

Currently two sizes of rope are being sold for Auto Towing applications namely $\frac{1}{2}$ ton and 1 ton. In the past 12 months more clubs have changed to the 1 ton size as they find it more economical and durable than the $\frac{1}{2}$ ton. It is of course heavier and more bulky but still seems to have practical advantages over conventional steel wire.

If there was sufficient sustained demand it would be possible to optimise on an intermediate size specifically for Glider use. It seems unlikely however that the civilian Glider usage would ever be sufficient without the adoption of the material as standard by the RAF/ATC.

Field Precautions

Parafil Rope is more susceptible to cuts and abrasions than steel wire. Discipline on the field is therefore important to stop people driving tractors and other vehicles across the Parafil Rope. Similarly all handling and storage equipment must have no sharp edges and be burr free. Perhaps it is significant that those clubs with inherent more disciplined members i.e. service clubs etc, seem to have a more success with Parafil than some other clubs.

Winches

Drum - Parafil has a much higher elasticity than steel wires and, therefore, considerable crushing pressures can develop on multi layer drums. This can cause damage of the lower layers and a breakdown of the protective sheath. Parafil Ropes have a bigger cross section than normal steel wire cables and therefore the drum capacity must be increased accordingly (this created problems on the ATC winch at Swanton Morley). It would seem that there are two possible solutions to these problems:

- a) A large diameter narrow drum winch.
- b) A two drum winch where the rope is stored on a low tension drum behind the main winching drum.

The storage drum would have to be driven by device which limited the torque and therefore the tension on the Parafil Rope. See sketch attached to this letter. Winches of this type have been developed for industrial and shipping uses, although I am not aware of any winch that is suitable size for Glider Launching applications.

Paying on Gear

Because of Parafil's vulnerability to damage Paying on Gear and Guide Rollers should be to a very high standard. All Rollers should have a low moment of inertia to avoid burning or melting of the sheath during the initial acceleration stage when the rope makes first contact with the Roller.

It would seem that either metal rim plastic rollers or hard anodised aluminium rollers would offer a solution to this problem.

Cable Breaks

Providing precautions are taken to prevent mechanical damage to the sheath and core yarns there is normally a very low incidence of cable breaks. Daily cable inspections should normally find sheath damage in sufficient time for it to be protected by the use of normal adhesive PVC tapes. Actual breakages have been repaired by using a conventional reef knot with approximately 18" long tail each side of the knot being taped back to the rope throughout their length. This method has proven to be only marginally successful. On Auto Towing applications proprietary terminals can be used to join the broken ends together. Terminals however would not be practical for a winch cable because of their rigidity and potential damage to the Guide Rollers, Paying On Gear, and adjacent turns on the drum. The writer is reasonably confident that breakages can be repaired by a simple splice although this would be tedious on the field. Alternatively laboratory tests with the reef knot indicate that it may be possible to provide the full strength of the rope by binding a sufficient overlap of rope (without the knot) with adhesive tape. Unfortunately, we were not able to prove this because the bed length of the test machine would not accept a long enough sample.

Our company will be pleased to provide technical assistance to any individual or club that wish to experiment with Parafil for winch launch applications. The extent of our help would naturally be dependant on the potential commercial sales and the attitude of the RAF/ATC to Parafil, assuming that the trials were successful.

Yours faithfully,
Precision Component Manufacturing Co (Southern) Limited.

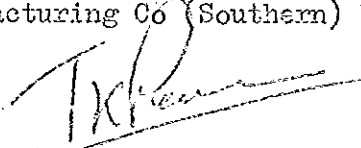
T.K. Pearce
Director.

Enclosure. Current price list and literature.

2 Drum Blower (PAPERFIL)

TWS 5/6/77

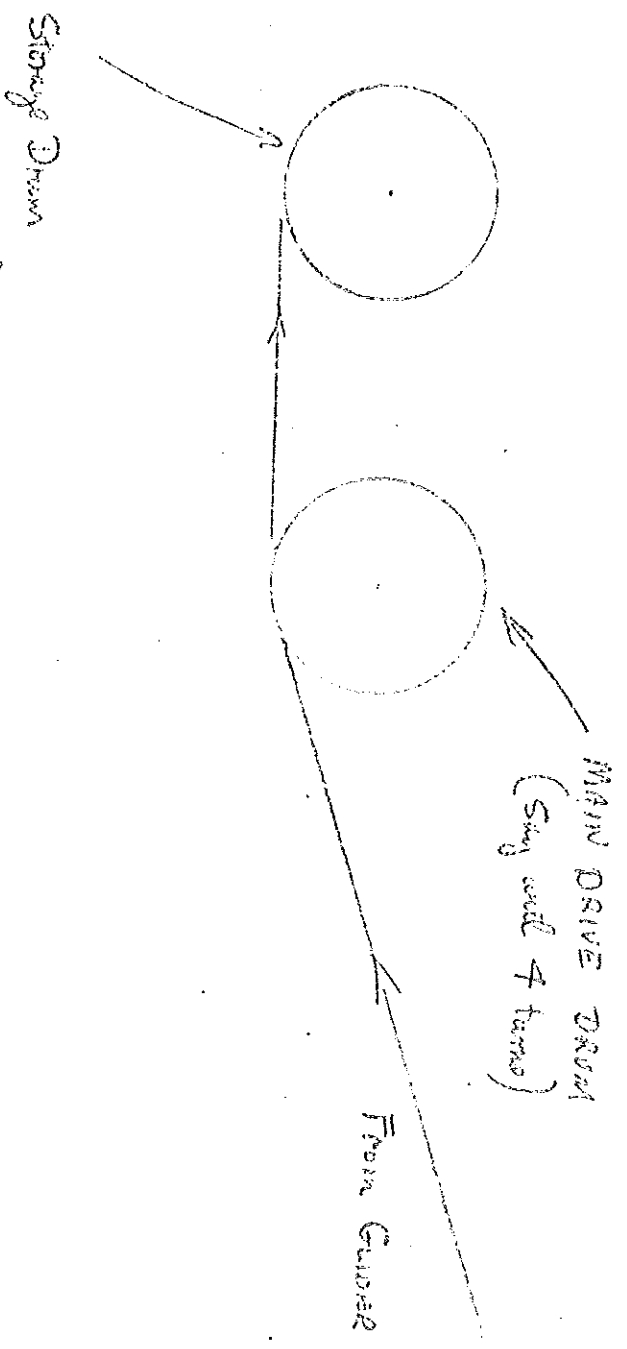

- 1) Limited torque
- 2) Surface speed of storage layer would be slightly slower than blower speed if Main Drum because of elastic recovery of rope under lower tension

TWS
1/1

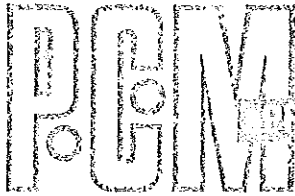

ROPE MANUFACTURING WORKS SOUTH BENFLEET

Manufacturers Engineers

Manufacturers D.G.I., A.H.B. and I.N.O. Main Contractors

19-21 Kents Hill Road · Benfleet · Essex · SS7 5PN Telephone · South Benfleet (03-745) 52711/2

Our Ref TYP/MH

Your Ref

Date 6.5.77

R.B. Stratton, Esq.,
Chief Technical Officer,
British Gliding Association,
Kimberley House,
Vaughan Way,
Leicester.

"PARAFIL" ROPES - JOINTS.

Dear Sir,

Further to my letter of the 22nd April. I have recently had the opportunity of doing more tests on the jointing of small Parafil Ropes. These were undertaken at the Sheffield Test House and can be supported by their certificates of performance. The number of tests were limited within the time available, but are sufficiently encouraging for me to say that I definitely think a taped joint is both possible and practical. The results were as follows:-

<u>Test Number</u>	<u>Rope</u>	<u>Overlap Length</u>	<u>Failure Load</u>
1	$\frac{1}{2}$ ton Type A	62 $\frac{1}{2}$ "	.38 tons
2	$\frac{1}{2}$ ton Type A	72"	.42 tons
3	$\frac{1}{2}$ ton Type A	119"	.68 tons
4	1 ton Type C	121"	.95 tons

The failure occurred on tests 1,2 and 3 because of insufficient adhesion and the two ropes dragged through the adhesive tape. There were only one or two small breaks in the tape where presumably that turn was under more stress than its neighbours. These tape tears did not appear to effect the result. The failure was progressive and, indeed, the load fell away steadily as the contact area was steadily diminished through the ropes sliding through the tape. Therefore it would seem that if used on Glider Ropes it is unlikely that a high shock load would break the joint unless it was repeated many times. Although tests 1 to 3 were done with Type A rope it is thought that a similar result would be obtained with Type C.

The failure in test 4 occurred because the core yarns pulled through the sheath. It would appear that the increased surface area of the larger rope gave sufficient friction/adhesive force for the tape to hold the two sheaths together.

cont...



If an opportunity occurs we intend to continue these experiments, varying both the length of the joint and also the type of sticky tape used. I enclose a sample of the tape used during the tests, which was a type on standard issue from our own stores and to my knowledge generally available.

I trust that you will find this information of help and possible use.

Yours faithfully,
Precision Component Manufacturing Co. (Southern) Limited.

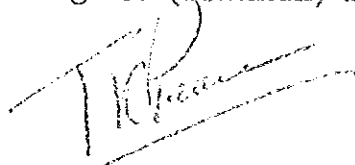
A handwritten signature in dark ink, appearing to read 'T.K. Pearce', written over a horizontal line.

T.K. Pearce
Director.