

B.G.A. TECHNICAL COMMITTEE

TECHNICAL NEWSHEET

TNS 9/10/86

---

PART I AIRWORTHINESS "AGGRO" (Please add to the 1986 Pink Pages)

- 1.1. I.S. 30 Undercarriage Collapse, following structural failure. The attached sketch is self-explanatory. Repair scheme from U.K. Agents.
- 1.2. M.200 Rudder detached The attached sketch indicates areas for DAILY INSPECTION following a failure at Northumbria G.C.
- 1.3. Ka7 Fatigue failure of the "V" bracket. Supporting the speed-brake lever, in the wing root, results in partial asymmetric deployment of the brakes (similar failures reported on Ka13s). (Enstone Eagles G.C.).
- 1.4. JANUS C.M. Mandatory Modifications Fuel system Tech-Note 809-3 (from U.K. agents) requires fuel pumps to be piped in parallel.
- 1.5. LS6 Flutter (leading to one case of abandoning the aircraft), has been notified to owners and LBA mandatory speed restriction of 108 knots has been imposed. Modifications to reduce the backlash in the flaps are required. (Notified to owners).
- 1.6. Centrair 101 "Pegasus" series - "Aileron Oscillations" French A/D T.86-129, places constraints on the use of water-ballast, and requires modifications to centrair BS N 101-7 before March 1987. (Notified by BGA to owners 20.8.86).
- 1.7. FAUVETTE Failure of the pivot supporting pilot's airbrake lever in the cockpit. Brittle brazing failed. (Reported by P.F. Woodcock).
- 1.8. T.65 'VEGA' Tailplane/Elevator flutter. The case reported in TNS 7/8/86 (1.3.) from R.A.F.G.S.A. (Germany), was caused by prior structural damage remaining undetected, from a previous incident. (Report from Slingsby Aircraft Ltd)
- 1.9. Grob 109 (A) Undercarriage Support Structure (below the seats). Cracks have been found in bracketry (partly embedded in G.R.P.) following heaving landing inspections. Could apply to early serial No. 109 (As). B.G.A. have discussed the problem with Grob. Anglia Sailplanes repair scheme has been approved.
- 1.10. SLICK MAGNETO's (applicable to Tugs & Motor-Gliders) The recent ditching of a Grob 109b has been confirmed as failure of the magneto (low time). After a short period of operation, total failure occurred, probably due to break-down of the H.T. Coil. (Mag was modified per B.G.A. TNS 7/8/86 (1.21) ).
- 1.11. SLICK S.B. 2-80-A (herewith), gives magneto maintenance and overhaul schedules.
- 1.12. C.A.A. Foreign Airworthiness Directives (updated) in respect of:
  - a) RF 3, 4, 5 & 6
  - b) DG 400
  - c) Taifun 17E, are enclosed herewith
- 1.13. Extracts from C.A.A. General Aviation Safety Information Leaflets (G.A.S.I.L. 7/86) refer to:-
  - a) PA-18 (Cubs) Stabilator screw-jack failure
  - b) PA-18 (Cubs) Lift-strut fork-ends, cracked
  - c) Soccata Rallye - Tailplane Corrosion
  - d) Slick Magneto's

- e) Composites & fuels
- f) Bendix MAG switches

1.14 SZD 51-1 "Junior" Sailplane. B.G.A. Mandatory Mods Whereas this type is not yet formally type certificated in the U.K. by the B.G.A. Technical Committee, the following modifications will be required even for a "Permit to Fly":

- a) Cable Release circuit - outer cable from the instrument panel bulkhead to the belly hook to be secured.
- b) Panel bulkhead to be reinforced, from behind.
- c) Bungee hook to be removed
- d) Canopy restraint straps to be more adequately secured.
- e) Cable Release knob attachment at the panel cowling to be bolted, not screwed.
- f) Drainage holes to be inserted (also for venting) in ailerons and rudder.
- g) Trim control lever to be coloured GREEN.
- h) Speed-brake lever to be coloured BLUE  
(Notified to Anglo Polish Sailplanes 20.8.86).

1.15 TOST WEAK-LINK ASSEMBLIES The bolts attaching these assemblies must be free to rotate, if the links are to operate at the correct overload conditions. (Notified by H.Q. Air Cadets).

1.16 Grob 109 (A & B) Alternate Carb (Hot) Air Shutters Screws securing the "butterflies" of both boxes have been swallowed by the engine. Inspect a.s.a.p., and secure by "locktite" or peening. Hot air system jammed.

## PART 2 GENERAL MATTERS

2.1. C.A.A. Light Aircraft Maintenance Schedules (LAMS Issue 2)

In order that operators can more effectively comply with the 50/150/ Annual cycle, and more fully understand the details of the inspections required, proforma versions are available from the B.G.A. office (copy attached).

2.2. Long-Life Wooden Gliders We understand that an ex Air Cadet Glider, having exceeded 36 years and 45,000 launches, likewise exceeded its proof and ultimate load tests!

2.3. KA 13 Disabled Person's Manual Rudder Conversion kit, has been devised and tested by R.A.F.G.S.A. Marham. Contact Sgt. A. Raffan 617 Sqn., R.A.F. Marham, Kings Lynn, Norfolk.

2.4. IS 30 - Service Bulletin EO-2 increases the "Maximum Admitted Take-off Mass" from 590 kgs to 610 kgs. New Placards should be available from the U.K. Agents.

2.5. B.G.A. INSPECTOR RENEWALS 1986/87

Inspector renewals become due October 1st 1986 (£15.00), and includes your personal liability insurance indemnity cover of £250,000 in respect of "activities and responsibilities directly in connection with airworthiness certification.

Please respond a.s.a.p. on the enclosed proforma.

B.B. STRATTON  
CHIEF TECHNICAL OFFICER  
23.9.1986

---

TWS 9/10/86  
1.2

# RUDDER DETACHES

M. 200

## M 200 RUDDER HINGE NOTE

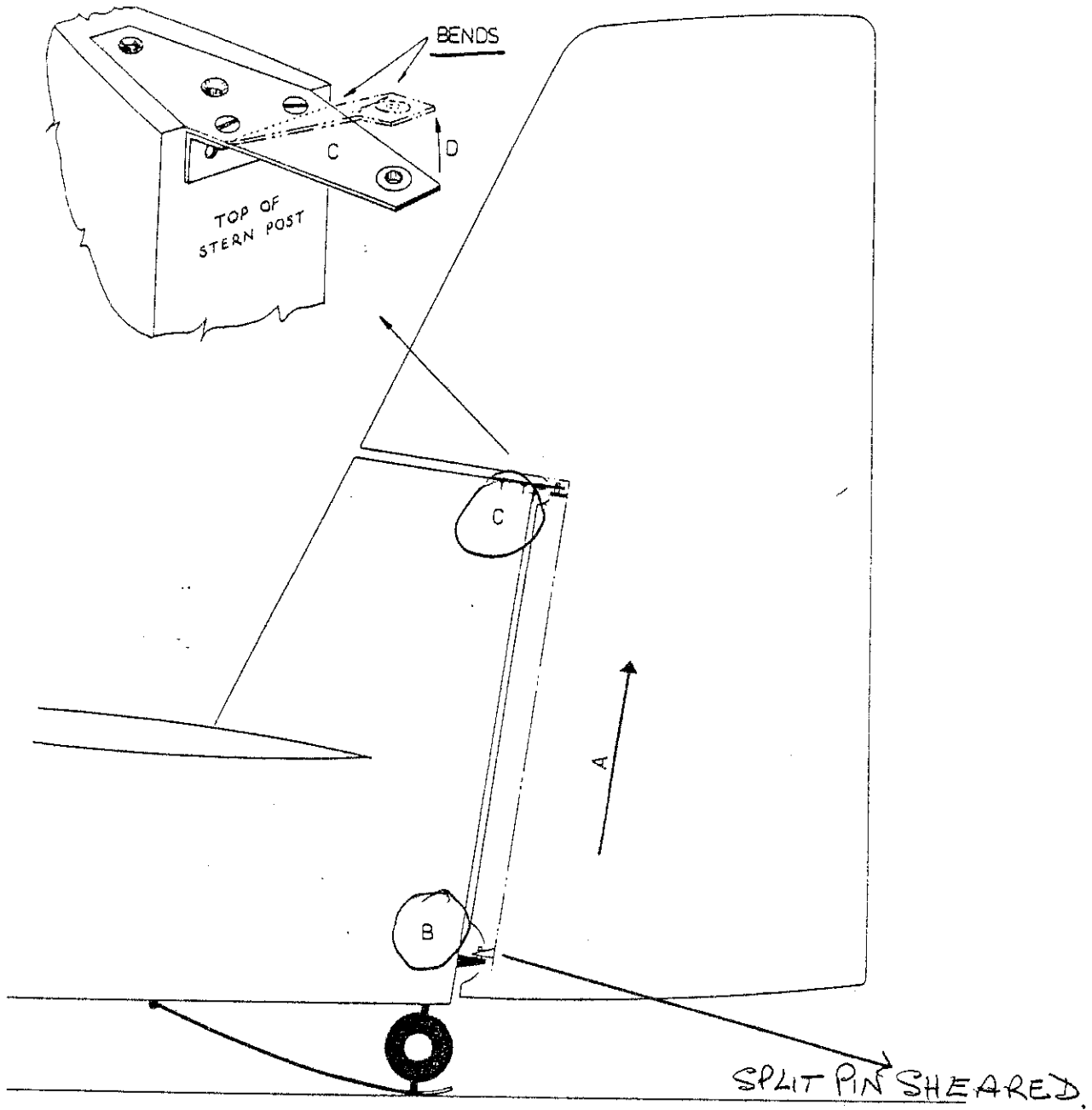

M. 200 Rudder Detached. INSPECTIONS As 1980

REQUIRED AT (C) and (B).

NORTHUMBRIA & C.

I.S. 30. 11. 11. 1986

REAR COCKPIT FLOOR

VIEW ON 'A'

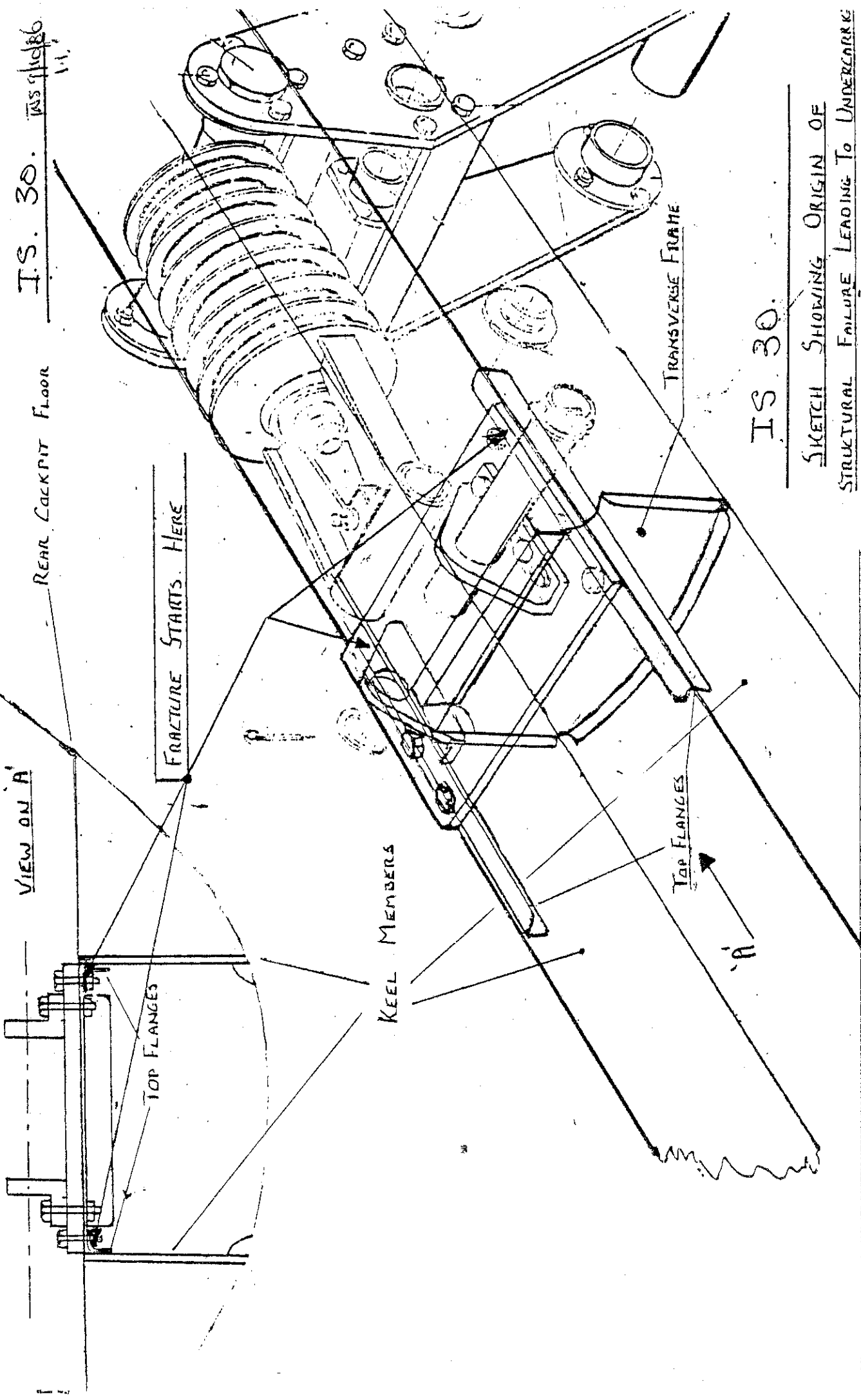

FRACTURE STARTS HERE

TOP FLANGES

KEEL MEMBERS

TOP FLANGES

TRANSVERSE FRAME

I.S. 30.

SKETCH SHOWING ORIGIN OF

STRUCTURAL FAILURE LEADING TO UNDERCARRIAGE

COLLAPSE IS 30 5/11/86 ON 17 JULY 1986

J. Eagles 26/2/86



CLASSIC AEROPLANE Ltd

Cheltenham, Glos. GL51 6SR.

Tel: Churchdown (0452) 856661



# Service Bulletin

**TO:** Aircraft Manufacturers, Aircraft Engine Manufacturers, Distributors, Dealers, Engine Overhaul Facilities, Owners and Operators of Slick Aircraft Magnetos.

**SUBJECT:** Magneto Maintenance and Overhaul Schedules

**BACKGROUND INFORMATION:** The service and warranty history of Slick magnetos clearly shows that the prescribed maintenance and overhaul schedules found in Slick Maintenance and Overhaul manuals F-1020 and L-1037 are not being followed. Failure to perform the prescribed inspections, maintenance, and overhaul procedures voids Slick warranty and may jeopardize the airworthiness of these components.

**CHECK WITH SLICK TO BE SURE YOU HAVE THE MOST CURRENT REVISIONS OF SLICK MANUALS F-1020 AND L-1037 AND PERTINENT SLICK SERVICE BULLETINS BEFORE PERFORMING MAINTENANCE OR OVERHAUL.**

**COMPLIANCE:** As required.

**PROOF OF COMPLIANCE:** Appropriate log book entries.

**MODELS AFFECTED:** All 400 and 600 series magnetos  
4000 and 4100 series magnetos  
4200 and 6200 series magnetos

**MAINTENANCE PARTS AFFECTED:** None

**PARTS REQUIRED PER BULLETIN:** None

**TOOLS REQUIRED PER BULLETIN:** None

ISSUED			REVISED			SLICK ELECTRO, INC. 530 BLACKHAWK PARK AVE. ROCKFORD, ILLINOIS 61101 U.S.A. * Slick Electro Inc. 1983 & 1983	PAGE NO.	REVISION
MO	DAY	YR	MO	DAY	YEAR		1 OF 4	A
02	01	80	12	01	83			

WEIGHT CHANGE: None

**DETAILED INSTRUCTIONS:**

400 and 600 Series Magnetos — Reference Manual F-1020

I. 100 Hour Inspection

- 1) Adjust timing to engine
- 2) General inspections
  - a) wiring connections and condition
  - b) vent holes
  - c) P-lead attachment

II. 500 Hour Inspection

- 1) Contact Points - check gap for setting and wear. Replace as necessary.
- 2) Carbon Brush - check for wear. Replace as necessary.
- 3) Impulse Coupling - check for wear. Replace as necessary.
- 4) Ball Bearing - check for end play and wear. Replace as necessary.
- 5) Other components (coil, condenser, etc) - check and replace as necessary.

In addition, all lubrication and cleaning as outlined in Manual F-1020 should be performed. Make sure the oilite bushings are oiled according to the instructions contained in Manual F-1020.

III. Overhaul

These magnetos should be completely overhauled as required by the inspections outlined above. They must be overhauled at every engine overhaul. In many instances, the mechanic may find it easier to replace a magneto with a factory assembled new or exchange unit than to perform the overhaul in the field.

IV. Replacement

These magnetos should be replaced as necessary when indicated by the above inspections.

4000/4100 Series Magnetos

I. 200 Hour Inspection

- 1) Adjust timing to engine
- 2) General inspections
  - a) wiring connections and condition
  - b) vent holes
  - c) P-lead attachment

ISSUED			REVISED			SLICK ELECTRO, INC.	PAGE NO.	REVISION
MO	DAY	YR	MO	DAY	YEAR			
02	01	80	12	01	83	530 BLACKHAWK PARK AVE. ROCKFORD, ILLINOIS 61101 U.S.A.	2 OF 4	A

## II. Overhaul

These magnetos are sealed at the factory, and no attempt should be made to overhaul them in the field. They are meant to be exchanged completely for new or Factory Rebuilt 4200 Series magnetos.

## III. Replacement

As a good maintenance practice, it is recommended that these magnetos be replaced at 800 hours of service. Some magnetos may need replacing at fewer hours, depending on the conditions to which the magneto has been subjected.

### 4200/6200 Series Magnetos - Reference Manual L-1037

#### I. 100 Hour Inspection

- 1) Adjust timing to engine
- 2) General Inspections
  - a) wiring connections and conditions
  - b) vent holes - non-pressurized magnetos
  - c) P-Lead attachment
  - d) turbo filter used with pressurized magnetos, model 6220 and 6224, should be inspected for contamination or discoloration. Filter will turn YELLOW or RED if contaminated. Replace as required.

#### II. 250 Hour Inspection (4200 series magnetos used on Avco Lycoming Division aircraft engines only.)

- 1) Ball Bearing Assembly
  - a) Perform the inspection only if the magneto was not converted to the improved bearing configuration. Converted magnetos can be identified by a letter "B" stamped in front of the serial number on the magneto dataplate.
  - b) Perform bearing inspection and maintenance as outlined in Slick Service Bulletin SB 7-83.
- 2) General Inspections
  - a) Contact Points - check for gap setting and wear. Replace as necessary.
  - b) Carbon Brush - check for wear. Replace as necessary.
  - c) Other Components (coil, condenser, etc.) - check and replace as necessary.
  - d) Lubrication - check and lubricate as outlined in Manual L-1037.
  - e) Cleaning - perform general wiring and cleaning maintenance.

ISSUED			REVISED			<b>SLICK ELECTRO, INC.</b> 530 BLACKHAWK PARK AVE. ROCKFORD, ILLINOIS 61101 U.S.A.	PAGE NO.	REVISION
MO	DAY	YR	MO	DAY	YEAR			
02	01	80	12	01	83	3 OF 4	A	

### III. 500 Hour Inspection

- 1) Contact Points - check for gap setting and wear. Replace as necessary.
- 2) Carbon Brush - check for wear. Replace as necessary.
- 3) Impulse Coupling - check for wear. Replace as necessary.
- 4) Ball Bearing Assembly - check for wear and grease condition. Replace as necessary. Reference Slick Service Bulletin SB 7-83.
- 5) Other Components (coil, condenser, etc.) - check and replace as necessary.
- 6) Lubrication - check and lubricate as outlined in Manual L-1037.
- 7) Replace turbo filter used with pressurized magnetos, model 6220 and 6224.
- 8) Cleaning - perform general wiring and cleaning maintenance. Clean inlet nozzle and vent orifice on pressurized magnetos. Clean vent plugs on non-pressurized magnetos

### IV. Overhaul

These magnetos should be completely overhauled when conditions indicate, following steps outlined in Manual L-1037. They must be overhauled at every engine overhaul. In many instances, the mechanic may find it easier to replace a magneto with a factory assembled new or exchange unit than perform the overhaul in the field.

### V. Replacement

These magnetos should be replaced as necessary when indicated by the above inspections.

**WARRANTY:** Void if prescribed maintenance schedules are not followed.

**CHECK WITH SLICK TO BE SURE YOU HAVE THE MOST CURRENT REVISIONS OF SLICK MANUALS F-1020 AND L-1037 AND PERTINENT SLICK SERVICE BULLETINS BEFORE PERFORMING MAINTENANCE OR OVERHAUL.**

ISSUED			REVISED			<b>SLICK ELECTRO, INC.</b> 530 BLACKHAWK PARK AVE. ROCKFORD, ILLINOIS 61101 U.S.A.	PAGE NO.	REVISION
MO	DAY	YR	MO	DAY	YEAR		4 OF 4	A
02	01	80	12	01	83	© 1983		



FOURNIER RF3 AND RF6 SERIES MOTOR GLIDERS

<u>CAA AD No</u>	<u>Associated Material</u>	<u>Description</u>	<u>Applicability - Compliance - Requirement</u>
------------------	----------------------------	--------------------	---

PART I - BUREAU VERITAS AIRWORTHINESS DIRECTIVES

67-39-1		<u>Wing Skin</u> - Inspection for cracks and deterioration of glued joints.	Applicable to all RF3 Series aircraft. INSPECT the critical zone every 30 flight hours until modified in accordance with Service Bulletin Alpavia No 2.
75-76		<u>Operating Limitations</u> - Normal category certification only.	Applicable to all RF3 Series aircraft. Install a plate in the cockpit on the wheel well with the following notice no later than 15 May 1975: 'U category operation and spins prohibited'.
79-234		<u>Fuselage</u> - Modification to the fireproof bulkhead - Installation of a seal supporting plate.	Applicable to all RF6B-100 aircraft. Compliance required as detailed in AD. Fournier Aviation Service Bulletin No 3 also refers.
79-235		<u>Flight Controls</u> - Inspection and replacement of aileron control coupling rod.	Applicable to all RF6B-100 aircraft. Compliance required as detailed in AD. Fournier Aviation Service Bulletin No 2 also refers.
86-31		<u>Aircraft Structure and Flight Controls</u> - Inspection for corrosion of metal parts.	Applicable to all RF6B-100 and RF6B-120 aircraft. Compliance required as detailed in AD. Fournier circular dated 10.01.1986 also refers.

SPORTAVIA-PUTZER RF4 AND RF5 SERIES MOTOR GLIDERS

<u>CAA AD No.</u>	<u>Associated Material</u>	<u>Description</u>	<u>Applicability - Compliance - Requirement</u>
	PART 1 - LUFTFAHRT-BUNDESAMT AIRWORTHINESS DIRECTIVES		
72-24		Remove ground handling bar from the fuselage and inspect for grinding marks in longitudinal direction of the fuselage centre-line.	Applicable to all RF5 aircraft. Compliance required as detailed in Airworthiness Directive.
72-25		Replacement of propeller boss bolts and centering bushings.	Applicable to all RF5 aircraft. Compliance required at next 100 hour inspection. Working Instruction A-04-72 and Service Letter S-02-72 refer.
83-15		Inspection/repair of aft fuselage and vertical fin spar.	Applicable to all RF4, RF4D, RF5 and RF5B aircraft. Compliance required as detailed in Airworthiness Directive. Technical Note S-02-82 also refers.
85-207		Inspection/replacement of elevator mounts.	Applicable to all RF4D and RF5 aircraft. Compliance required as detailed in Airworthiness Directive. Technical Note S-01-85/1 also refers.

GLASER-DIRKS DG-400 SERIES MOTOR GLIDERS

<u>CAA AD No.</u>	<u>Associated Material</u>	<u>Description</u>	<u>Applicability - Compliance - Requirement</u>
<u>PART I - LUFTFAHRT-BUNDESAMT AIRWORTHINESS DIRECTIVES</u>			
83-171		Flexible wing fuel tanks.	Applicable to DG-400 Serial Nos as detailed in Airworthiness Directive. Compliance required as detailed in Airworthiness Directive. Glaser-Dirks Technical Note 826/3 also refers.
84-155		Rotax 505 engine, canopy jettison device, DEI, towing cable release mechanism.	Applicable to DG-400 Serial Nos 4-1 to 4-87. Compliance required as detailed in Airworthiness Directive. Glaser-Dirks Technical Note 826/6 also refers.
84-157		Power plant, vibration cracks.	Applicable to DG-400 all Serial Nos. Compliance required as detailed in Airworthiness Directive. Glaser-Dirks Technical Note 826/11 also refers.
85-219		Replacement of fuel shut off valve gaskets.	Applicable to DG-400 Serial Nos 4-1 to 4-140. Compliance required as detailed in Airworthiness Directive. Glaser-Dirks Technical Note 826/14 also refers.
85-223		Powerplant - cable guides - inspection to prevent possible fouling of engine extension.	Applicable to DG-400 Serial Nos 4-1 to 4-140. Compliance required as detailed in Airworthiness Directive. Glaser-Dirks Technical Note 826/15 also refers.

<u>CAA AD No</u>	<u>Associated Material</u>	<u>Description</u>	<u>Applicability - Compliance - Requirement</u>
	86-138	Improved marking of canopy emergency release and re-location of ventilation placard.	Applicable to DG-400 Serial Nos 4-1 to 4-176. Compliance required as detailed in Airworthiness Directive. Glaser-Dirks Technical Note 826/16 also refers.

REG TNS 9/10/86

Issue 3  
August 1986

VALENTIN TAIFUN 17E MOTOR GLIDERS

<u>CAA AD No</u>	<u>Associated Material</u>	<u>Description</u>	<u>Applicability - Compliance - Requirement</u>
		<u>PART I - LUFTFAHRT - BUNDESAMT AIRWORTHINESS DIRECTIVES</u>	
85-29		<u>Flight Controls</u> - Elevator control connection. Tailplane mounting. <u>Landing Gear</u> - Actuating struts of main gear and nose gear. Securing the bearing of the main landing gear.	Applicable to all Serial Nos. until 1032. Compliance required as detailed in Airworthiness Directive. Valentin Technical Information 3/818 also refers.
		<u>Electrical Power</u> - Push button starter.	
		<u>Fuel</u> - Emergency fuel shut-off valve.	
85-129		Improvement of the stall characteristic.	Applicable to all Serial Nos. Compliance required as detailed in L.B. Airworthiness Directive. Valentin Technical Information 4/818 also refers.
85-263		Installation of a stall warning device.	Applicable to all Serial Nos. Compliance required as detailed in Airworthiness Directive. Valentin Technical Information 8/818 also refers.

<u>CAA AD No</u>	<u>Associated Material</u>	<u>Description</u>	<u>Applicability - Compliance - Requirement</u>
	86-137	Inspection and modification of tailplane front mounting.	Applicable to all Serial Numbers. Compliance required as detailed in Airworthiness Directive. Valentin Technical Note 10/818 also refers.

UPDATED INFORMATION

G-AS-LL 7/86 -

E BRATNs/9/10/86

15. Issue 11/85 - Item 10 and 12/85 - Item 24 Piper PA18-150  
New Stabilator  
Jackscrew Broke Easily

Thanks to the excellent co-operation of Air Part Supply Ltd the new horizontal stabiliser jackscrew Part No 42961-02 which failed was returned to Piper Aircraft who supplied it. They state there is no evidence of defect in material or workmanship, however, a foreign substance, possibly RTV, was in the grooves and there was evidence of a press mark on the break. They consider the matter closed.

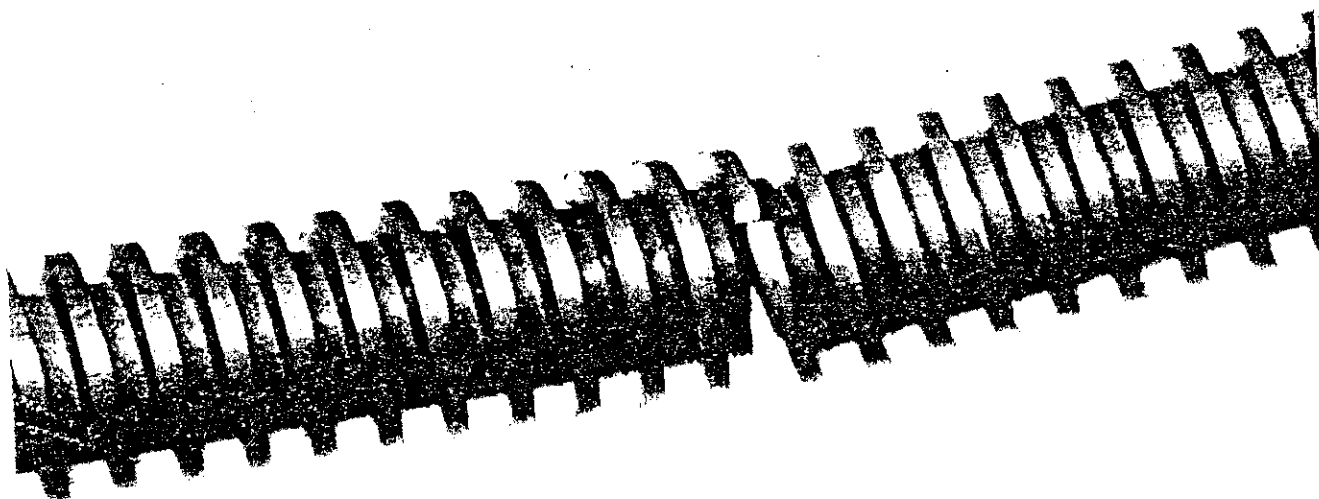

8

5. LIFT-STRUT FORK ENDS CRACKED

E

Aircraft : Piper PA18-150 Super Cub (and other Piper high-wing aircraft)  
Date : April 1986

The lift-strut fork ends were removed for magnetic particle inspection in accordance with FAA AD 81-25-05. Three out of the four were found to have axial cracks in the fork-end fitting and in the threaded portion. The aircraft and the component had flown 976 hours, with 500 since the last magnetic particle inspection. The part is allowed 1000 hours operation by Piper SB 157D.

Dye penetrant inspection failed to indicate any defect.

CAA Comment:

A letter was sent to all owners of Piper high-wing aircraft on 11 June 1986. This required inspection within 10 flight hours unless accomplished within the previous 240 hours. Any cracks found were to be reported to the SDAU.

The aircraft is used for glider towing, which may result in greater wear and tear than originally envisaged. This should be considered by operators when deciding on component lives and inspection periods. CAA AD 008-06-86 refers.

CASIL 7/86  
BRA TNS 9/10/86  
E

16. FUEL TANK & ATTACHMENTS - SEVERE CORROSION

Aircraft : Cessna F150K  
Date : June 1986

During a C of A renewal both tank access panels were removed for detailed inspection and tank tests. The left rear attachment strap on the left main fuel tank was found to be broken through due to corrosion. When the tank was removed the lower surface was found to be porous as a result of corrosion pits. The right fuel tank was removed and found in similar condition. Visual inspection through the tank filler cap showed no indication of these problems. Tank total hours 6490.

E

17. ELEVATOR TRAILING EDGE SKINS CREASED

Aircraft : Piper PA38 Tomahawk  
Date : July 1986

During a 150 hour inspection, the trailing edge skin of the right elevator was found excessively creased 2" and a further 6" outboard from the root end rib, forming a shallow 'S' between them. The left elevator was also found in a similar condition, 2" and a further 3" from the root end outboard.

The actual causes are not known to the reporter but he considers that they may be attributable to excessive loading whilst in certain manoeuvres during training, i.e. spin, dive or steep turn.

No other damage was found at the tailplane, fin or elevator attachments. Aircraft total hours 3925.

UPDATED INFORMATION

18. Issue 1/86 - Item 18 SOCATO Rallye - Corrosion of Structure

P/E

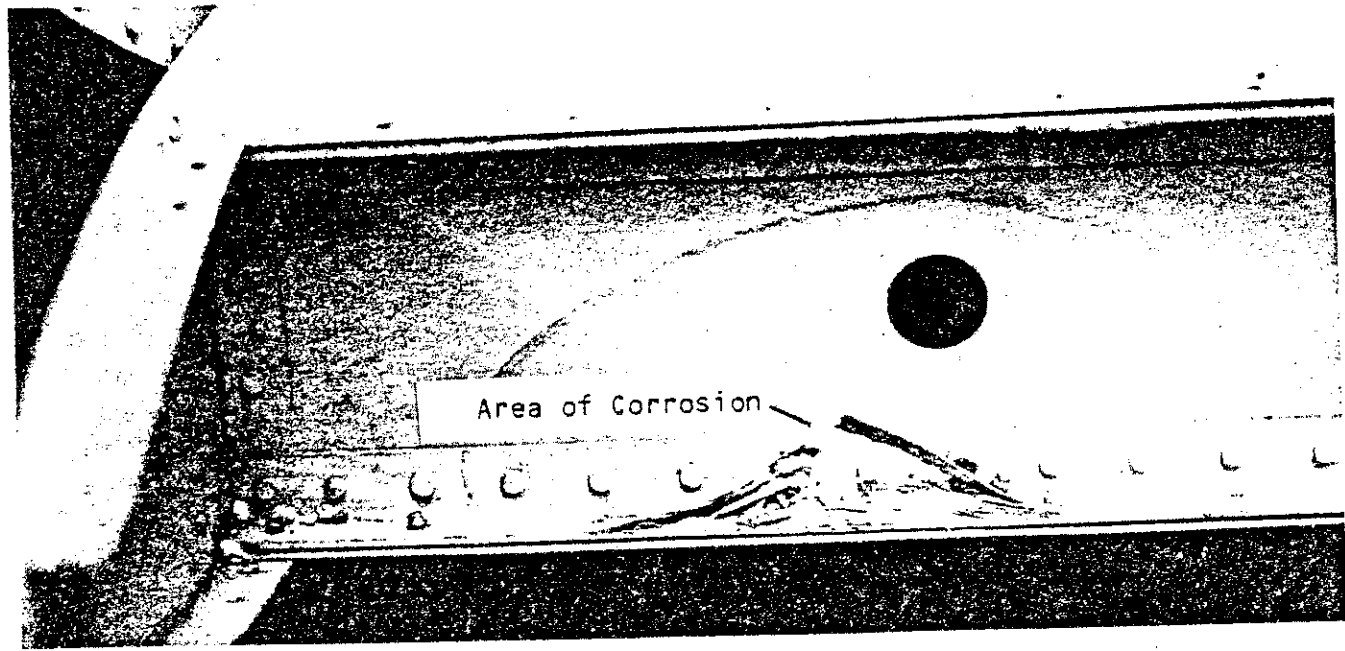

Another case has been reported to us of severe corrosion on the extended sections of the tailplane front spars. On one side it was apparent when the outer skin was examined, but on the other side, the leading edge had to be removed. The aircraft had flown 687 hours from new. Reference CAA AD 002-02-84.



12. MAGNETOS WORN

SLICK AGAIN!

E

CASIL 9/86

Aircraft : Gulfstream American AA5  
Date : May 1986  
Engine : Lycoming O-320

At the Annual Check with the engine hours at 963, the Slick 4200 Series magnetos were given a 500 hour inspection as per Slick maintenance and overhaul instructions. The electrodes of both magneto distributor rotor gear assemblies were found to be loose and worn in the nylon gear assembly. The block and gear assemblies Part No M3131 were replaced. There was no record of previous magneto inspections.

6

7. OIL COOLER LEAK

P/E

Aircraft : Socata TB9 Tampico  
Date : July 1986

The pilot became aware that a stream of oil was running up the windshield. He declared an emergency and returned to the nearby aerodrome for a priority landing.

The leak was due to a crack in the oil cooler, which had been replaced three weeks earlier due to a similar crack discovered during a post-flight check (shortly after a 150 hour check). The engineer is investigating any contributory engine factors.

VIBRATION?

CAA Comment:  
Have other owners/operators experienced this problem?

8. DANGERS OF FUEL ON COMPOSITE AIRCRAFT

P/E

The following Advisory Circular May 1986 appeared in the Australian Dept of Transport Airworthiness Information:

"The Department conducted a basic investigation of the compatibility of fuels with core materials used in composite construction. The fuels used were 100/130 Avgas, 100LL Avgas and both leaded and unleaded Mogas. Core samples were urethane, styrofoam and PV foam. It was found that while 100/130 Avgas had no effect on any sample, the styrofoam sample dissolved in 100LL Avgas within 5 minutes and in Mogas (both types) within 45 seconds. The other core samples were not affected.

The investigation was not exhaustive. However, the tests do confirm that 100LL Avgas is as potentially harmful to composite structures as Mogas.

It is arguable that a properly-cured laminate without any cracks will protect the underlying foam, but it would be imprudent to rely on this. Also, amateur-built composite aircraft were approved on the basis of a satisfactory service history, but the service history might well have been established using a less deleterious fuel.

Thus, in composite aircraft, 100LL fuel should only be used with great care and attention to structural integrity and its use avoided as far as possible."

CAA Comment:  
Samples of core foam from a typical composite aircraft being constructed in the UK were exposed to fresh samples of 100LL and 4 star Mogas to BS4040. As the photos show, 100LL had little effect whereas Mogas caused an almost instantaneous effect and within 30 seconds lumps were breaking off the foam, after 90 seconds the whole sample had completely disappeared. 5 minutes exposure to 100LL caused little visible effect on the foam.

30 seconds-  
large lumps  
falling off

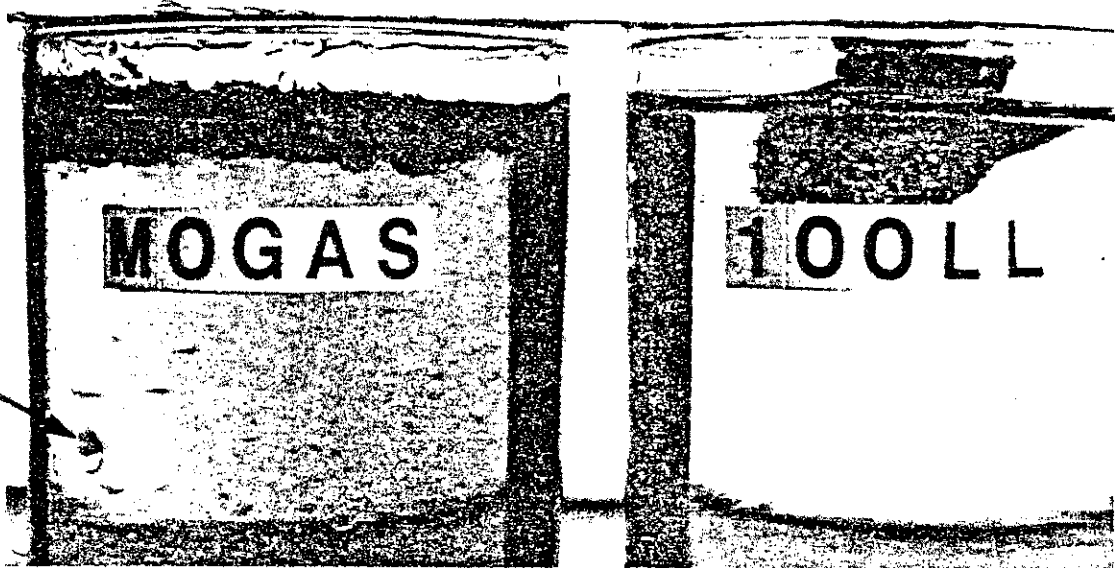

60 seconds-  
almost gone

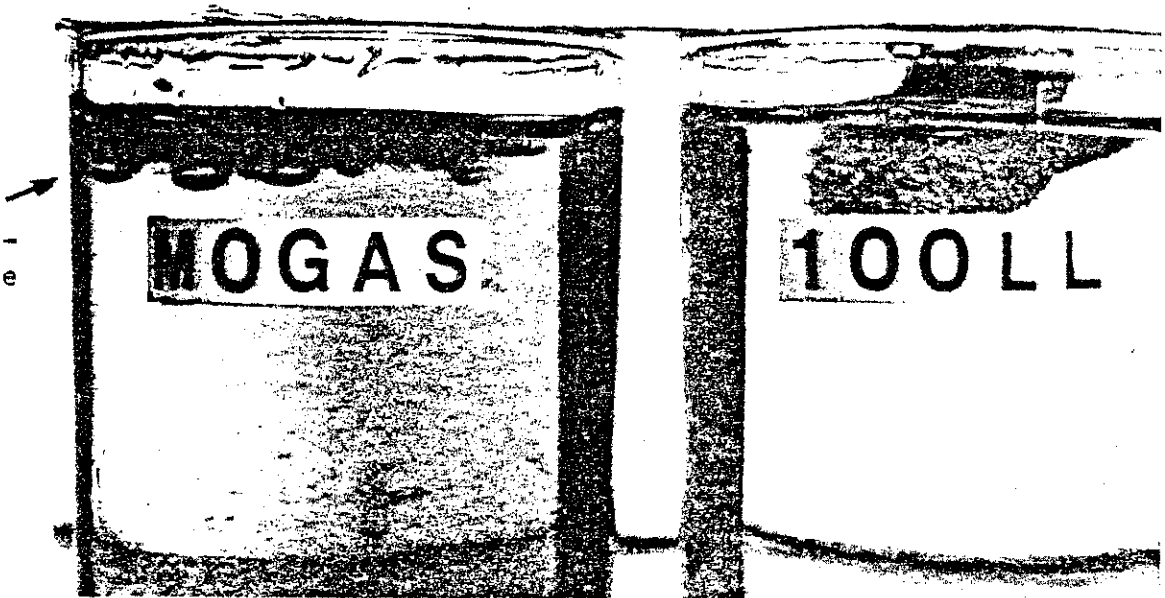

As the Australian article states 'a properly-cured laminate without any cracks will protect the underlying foam'. However, the effect of a leaking tank, spillage during re-fuelling etc. must be considered, **particularly in areas where fuel would not normally be expected.** It is suggested that anyone constructing a composite aircraft should check a sample of foam core used in their aircraft with both types of fuel.

#### 9. CORRODED FUEL VALVE

P/E

Aircraft : Gardan GY80 Horizon  
Date : May 1986

When switching from the right-hand fuel tank to the left-hand fuel tank, the engine stopped, with the fuel pressure showing zero. On reselecting the right-hand tank and using the electric pump, the engine started.

The fuel cock was found to be badly corroded and as spring pressure is required to operate the opening sequence in the fuel ports, the left-hand tank supply remained closed. The aircraft had been out of use for several years.

3. MAGNETO SWITCH ROTATED IN PANELBENDIX.

P/E

Aircraft : Gulfstream A45A (and other aircraft)  
Date : May 1986

An engineer was asked to investigate the reason for dead magnetos on the aircraft. It was found that the switch had rotated in relation to the markings on the panel.

This can be prevented by installing Bendix backplate Part No 10-51127. The reporter knows of three previous cases.

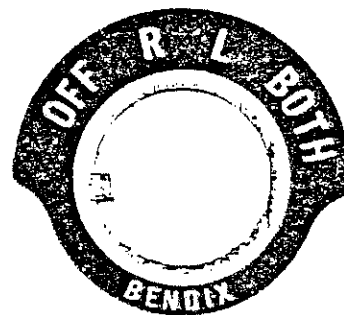

## CAA Comment:

All operators would be well advised to fit this plate (prevention is better than cure!). Pilots should be alert for loose switches and make certain that they have BOTH magnetos for take-off etc.

The minimum order for these plates is 50. Falcon Flying Services at Biggin Hill have purchased 50 and can supply other users.

4. LUTON SRZ INFRINGEMENTS

P

In the June GASIL we reminded those flying to the RFA Rally at Cranfield to stay out of the Luton airspace, unless authorised by ATC.

The following infringements were noted on radar as en-route to or departing from Cranfield.

Friday 4 July - 4 incidents at 11.20, 12.20, 17.23 and 18.54

Saturday 5 July - One incident at 12.58 (weather 3/8 at 800ft, 6/8 1200ft, visibility 9km), resulting in delays to two holiday jets.

Sunday 6 July - 6 incidents at 10.40, 11.48, 12.06, 12.54, 15.30 and 16.28.

If you were in the area at any of these times, and not too sure of your position, beware, you were spotted!

**UNLESS YOU HAVE BEEN CLEARED, STAY OUT OF REGULATED AIRSPACE, WE DO NOT WANT AN AEROMEXICO TYPE INCIDENT HERE**

5. FAULTY ALTIMETER

P/E

Aircraft Part : United Instruments Altimeter  
Date : July 1986

A new altimeter was unpacked from its transit case prior to fitment in a homebuilt aircraft. The adjustment mechanism was found to be out of rig with the barometric scale. The United instruments 5934P was outside the Serial Number range of CAA AD 86-05-02.

The instrument repair organisation found that the baro knob was damaged allowing the baroscale to be reset without moving the pointers. The unit was out of calibration so the capsule was reset. A new locking stud was fitted to the baro knob and the unit satisfactorily calibrated to specification.



CAA Light Aircraft Maintenance Schedule

CHECK A DAILY

- |   |                                |   |
|---|--------------------------------|---|
| 1 | <b>General</b>                 | Remove frost, snow or ice, if present.<br>Check that the aircraft documents are available and in order.<br>Ensure all loose equipment is correctly stowed and the aircraft is free of extraneous items.<br>If the aircraft has not been regularly used, ensure before resumption of flying that:<br>(a) Either (i) the engine has been turned weekly or run fortnightly,<br>or (ii) the manufacturer's recommendations have been complied with.<br>(b) Compression appears normal when engine turned by hand.<br>(c) Previously reported defects have been rectified. |
| 2 | <b>Power-plant/<br/>Engine</b> | Check – oil level; security of filler cap and dipstick.<br>Inspect – engine, as visible, for leaks, signs of overheating, and security of all items.<br>Inspect – air filter/air intake for cleanliness.<br>Check – security of cowlings, access doors and cowl flaps.  |
| 3 | <b>Propeller</b>               | Inspect – blades and spinner for damage and security.   |
| 4 | <b>Windscreen</b>              | Inspect – for damage and for cleanliness.   |
| 5 | <b>Fuel System</b>             | Check visually that quantities are compatible with indicator readings.<br>Drain fuel sample from each drain point into a transparent container and check for water, foreign matter and correct colour.  |
| 6 | <b>Wings</b>                   | Inspect – skin/covering, bracing wires, struts and flying control surfaces for damage and security of all items.<br>Inspect – pitot/static vents, fuel vents and drain holes for freedom from obstruction.<br>Test operation of stall warning device.   |

Sept 84

7/1

LAMS Fixed Wing – Section 7

- |    |  |   |
|----|--|---|
| 7  | <b>Landing Gear</b>                              | Check – shock-absorber struts for leaks and that extension appears normal.<br>Check – tyres for inflation, damage and creep.<br>Inspect – brake installation for external evidence of leaks, and for damage and security.   |
| 8  | <b>Fuselage and<br/>Empennage</b>                | Inspect – skin/covering, bracing wires, struts and flying control surfaces for damage and security of all items.<br>Inspect – drain holes and vents for freedom from obstruction.<br>Inspect – radio aerials for damage and security.   |
| 9  | <b>Cabin Area</b>                                | Check – flying and engine controls, including trimmers and flaps, for full and free movement in the correct sense.<br>Check – brake operation is normal.<br>Check – instrument readings are consistent with ambient conditions.<br>Perform manual override and disengagement check on auto-pilot.<br>Check – avionic equipment operation, using self-test facilities where provided.<br>Inspect – seats, belts and harnesses for satisfactory condition, locking and release.<br>Check – emergency equipment properly stowed and inspection dates valid.<br>Test operation of electrical circuits.<br>Inspect – cabin and baggage doors for damage, security, and for correct operation and locking.<br>Check that markings and full complement of placards are correctly positioned and legible. |
| 10 | <del><b>Agricultural<br/>Installations</b></del> | <del>Inspect – hopper, hopper lid, tank, pump, fan, boom assemblies, pipe runs, blowers and spreaders for damage and security.<br/>Check – emergency dump doors, fan brake and pump control for correct operation.</del>  |

NOTE: At the conclusion of agricultural operations the aeroplane shall be completely cleaned to remove chemicals, and an inspection of those parts of the aircraft structure which are likely to have been contaminated, eg skin/covering and exposed control cables, shall be carried out before the aeroplane is returned to any work other than agricultural operations.

Date/Sign

DOCUMENTATION

Tech Log/DI Book Defects - rectified	
Special Inspections (Section 10/LAMS)	
Mandatory MODS/A.D.'s/	
T.N.S.CAA Notices	
Certificate of Return to Service	
C of A valid to: .....date	
Log Book Entries	

OPERATIONAL CHECK-OUT

Parking-brake	
Panels secure	
Starting/Dead-Mag check	
Generator/Vacuum	
Mag Check	
Full Power	
Check RPM	
Oil Press/Oil Temp	
CHT Temp	
Carb/Cabin Heat	
Idle RPM	
Mixture check/ Cut-off	
Avionics, aerial Installations	

GENERAL REMARKS

(Future spares required, C/Fwd deficiencies etc.)

RETURNED TO SERVICE BY: Sign.....Date.....

LIC/INSP Ref:.....

Next Check due at:.....HRS.....Date.

Airframe Hours \_\_\_\_\_

A/C Registration \_\_\_\_\_

Engine Hours \_\_\_\_\_

Location \_\_\_\_\_

Date \_\_\_\_\_

**LAMS Fixed Wing – Section 7**

**50 HOUR, 150 HOUR AND ANNUAL CHECKS**

	Item	Detail*	50	150	Annual
Structures	1	Inspect – external covering of fuselage, tail booms, mainplanes, nacelles, empennage, control surfaces, flaps and other high lift devices. Inspect – normal and emergency windows and doors, and Check – satisfactory operation of latching and locking. Check – protective treatments; drain holes free from obstruction; access panels secure.	X	X	X
	2	Remove sufficient detachable panels and covers to Inspect – internal structure of fuselage, floors, bulkheads, tail booms, main planes, nacelles, empennage, control surfaces, flaps and other high lift devices, structural attachment joint assemblies; struts; bracing wires and their attachments; internal protective treatments; surface de-icer systems. Check – condition of static discharge wicks.		X	X
	3	Check – function of emergency exits by internal and external release methods. Inspect – condition of lightning strike bonding.			X
Landing Gear	4	Inspect – landing gear assemblies; shock-absorber struts or units for leaks and correct extension; brake system; wheels and tyres. Check – tyre pressures; hydraulic brake system fluid level(s).	X	X	X
	5	Prior to raising aircraft carry out Item 4. With aircraft supported and weight off the wheels, Inspect – structural members and attachment fittings, including pivot points; shock absorbing devices; bungee rubbers; torque links; main, nose/tail wheels, including bearings, skids; brake linings;		X	X

\*Inspection Required shown X

**LAMS Fixed Wing – Section 7**

	Item	Detail*	50	150	Annual
Landing Gear	5	drums/discs, anti-skid devices, hoses and lines; hydraulic and electric actuators and jacks. Check – main and parking brake systems for correct operation. Carry out normal and emergency retraction and extension checks, including operation of locking devices, doors and operating linkage, indicators and warning devices. Check – hydraulic/pneumatic operating pressures.		X	X
Flying Controls	6	Check – flying controls for full and free movement in the correct sense; position indicators agree with surface movement.	X	X	X
	7	Inspect – hinges; brackets; push-pull rods; bellcranks; control horns; balance weights; cables; pulleys; chains; tubes; guides and fairleads; rollers; tracks and rails; screw jacks/rams, including auxiliary gearboxes or other power-operated systems. Check – turnbuckles/locking devices in safety. Inspect – flap asymmetric protection mechanisms.		X	X
	8	Check – all control cables for correct tension; control neutrals and travels. Record results.			X
Liquid, Air, Gas Systems	9	Inspect – hydraulic, pneumatic, vacuum and other fluid systems, as visible, for leaks and damage. Check – fluid levels in reservoirs; accumulator pressures; pitot/static vents clear; drains free from obstruction and pitot head correctly aligned.	X	X	X
	10	Check – tanks; powerpacks; valves; pipelines; hoses; actuators; filters; venturis. Check – systems for leaks with system pressures during engine ground run.		X	X
	11	Check – pitot/static systems for leaks. <span style="float: right;"><i>Continued on page 716</i></span>			X

\*Inspection Required shown X

LAMS Fixed Wing – Section 7

	Item	Detail*	50	150	Annual
Equipment and Environmental	12	Check – correct stowage of equipment, and validity of date on emergency equipment; seats, belts/harnesses for satisfactory condition, locking and release; fire extinguishers for leakage or discharge.	X	X	X
	13	(a) Check – cabin air system for correct operation. Inspect – heater for signs of over-heating or contamination. Check – air conditioner for leaks and correct oil level. Inspect – ventilator blower; outflow valves; pressurization controller; bleed system; shut-off valves.		X	X
		(b) Carry out ground function pressurization check.			X
	14	Check – fire extinguisher(s) contents by pressure/weight.			X
Instrument Systems	15	Inspect – instruments for damage, and for legibility of markings and associated placards. Check – readings are consistent with ambient conditions; operation, as far as possible, on engine ground run; stall warning device operation.	X	X	X
	16	Inspect – instruments; panels; mounts; pipes; hoses; electrical wiring; gyro filters; flux detectors; instrument transmitters.		X	X
	17	Ensure – last compass swing will remain valid until next check (see Section 3, para 2.2(d)); instrument calibration periods will remain valid until next check (see Section 3, para 2.2(c)).	X	X	X
Auto-pilot & Flight Director	18	Inspect – displays; instruments; controllers. Check – operation, as far as possible, on engine ground run, and perform manual override and disengagement checks.	X	X	X
	19	Inspect – computers; amplifiers; power supplies; servo motors; connections to flying control systems; automatic trim systems; yaw dampers; manometric systems interconnections.		X	X

\*Inspection Required shown X

LAMS Fixed Wing – Section 7

	Item	Detail*	50	150	Annual
Electrical Systems	20	Maintain battery. Inspect – battery stowage/compartment and vents/drains. Check – operation of all electrical circuits.	X	X	X
	21	Inspect – components; wiring; terminals; connectors. Check – correct type and rating of fuses and circuit breakers; correct spare fuses carried; flap asymmetric protection and all travel limit microswitches; lamps and lighting; fire circuits; brushes in starters and generators; drive belt tension and condition. Ensure voltage regulator load sharing is correct.		X	X
Radio	22	Inspect – aerials; insulators; controllers; instruments and displays; microphones and headsets. Check – placards and markings legible. Carry out VHF ground function test.	X	X	X
	23(a)	HF Communication – Test the function of the system.			X
	23(b)	ADF – Carry out ground function test using station(s) of known bearing to establish bearing accuracy. Check – audio on all bands.			X
	23(c)	ILS Localiser and Glide Slope – Carry out a check with a Field Test Set, including flag warnings of single tone failure. Check – centre-line accuracies, sense and course widths. Check – audio.			X
	23(d)	VOR – Carry out a check with a Field Test Set, including flag warnings, omni-radial resolving and radio-magnetic indicators accuracy at 90° intervals. Check – sense and course width.			X

Continued on page 7/8

\*Inspection Required shown X



LAMS Fixed Wing – Section 7

	Item	Detail*	50	150	Annual
Radio	23(e)	Marker – Carry out a check with a Field Test Set, including 3-tone operational check. Check – High/Low sensitivity.			X
	23(f)	DME – Carry out a check with a Field Test Set, including range accuracy.			X
	23(g)	ATC Transponder – Carry out a check with a Field Test Set. Check – frequency tolerance and side-lobe suppression. Check – Mode 'C'.			X
	23(h)	Airborne Search/Weather Radar – Test the function of all modes.			X
	23(i)	Area Navigation – Establish accuracy of waypoint distance and bearing.			X
	23(j)	Audio – Check 'Emergency' operation.			X
	24	Verify by reference to Section 8 that all required maintenance activities have been complied with (see also Section 3, para 2.2(f)).	X	X	X
	25	Inspect – cables and terminals; cooling systems; moisture trap areas.		X	X
Lub	26	Lubricate aircraft in accordance with manufacturer's recommendations.	X	X	X
Propeller	27	Inspect – blades for damage. Check – accumulator/dome pressure.	X	X	X
	28	Inspect – spinner; backplate; constant speed unit (governor); accumulators; de-icing boots; slip rings/brushes; fluid systems; control systems. Check – pitch change mechanism for backlash; propeller hub for condition. Lubricate and check for oil leaks.		X	X

\*Inspection Required shown X

LAMS Fixed Wing – Section 7

	Item	Detail*	50	150	Annual
Engine Installation	29	Engine controls – Check for full and free movement of throttle, mixture and propeller controls over correct range.	X	X	X
	30	Check for evidence of leaks, overheating or other unsatisfactory operation.	X	X	X
	31	Inspect – crankcase; accessory housings; cylinder assemblies; valve operating mechanism; accessory drive belts; accessories; engine shock mounts; mount frames; bulkheads, firewalls and sealing; cooling baffles; cowlings; items in engine bay for mutual interference; compressor, turbine and gear housings; breathers and vents. Carry out compression check and record results and method used.		X	X
Air Induction	32	Inspect – air filter/intake for condition and cleanliness; induction system and first stage compressor impeller for damage.	X	X	X
	33	Check – security of induction system components; correct operation of carburettor heat; alternative air bypass doors; flame traps; control systems; drains.		X	X
Fuel	34	Inspect – filters for cleanliness. Drain samples from all drain points and check for water, foreign matter and correct colour. Check – tank vents unobstructed.	X	X	X
	35	Inspect – tanks; selector valves; pumps; pipelines; hoses; carburettors; injector systems; throttle, mixture and fuel selector controls; turbine fuel control units; nozzles.		X	X

Continued on page 7/10

\*Inspection Required shown X

LAMS Fixed Wing – Section 7

	Item	Detail*	50	150	Annual
Ignition	36	Inspect – magnetos; harnesses; spark plugs; switches; starting vibrators; contact breakers. Check – magneto internal timing and timing to engine. Assess condition of plug leads and HT harnesses. Service and test spark plugs (but see Section 3, para 2.2(e)). Check – magneto cam lubrication and ventilators; turbine ignitors and ignition units.		X	X
	37	Inspect – exhaust manifolds and mufflers for leaks, damage and security.	X	X	X
Exhaust	38	Remove cabin heat exchanger shrouds and inspect for signs of exhaust gas leakage. Inspect – turbo-charger (especially for cracks in turbine housing, compressor damage and freedom of rotation). Check – wastegate for correct operation. Inspect – turbo-charger control system, pipelines and hoses.		X	X
	39	Carry out pressure test of cabin heat exchanger.			X
Lubrication	40	Inspect and Check – filters; screens; magnetic plugs. Change oil (but see Section 3, para 2.2(e)).	X	X	X
	41	Inspect – tanks; sumps; coolers; hoses; pipelines; vents. Lubricate engine and controls as required by manufacturer.		X	X

\*Inspection Required shown X

7/10

Sept 84

LAMS Fixed Wing – Section 7

	Item	Detail*	50	150	Annual
	42	Ensure that:– (a) All tools, rags or other loose articles are removed from the aircraft. (b) All mandatory requirements (modifications, inspections and other directives) have been complied with.	X	X	X

Item 42(c) amend to read:

All manufacturers recommendations have been evaluated in accordance with Section 3 para 2 and any applicable requirements identified detailed in Sections 10 and 11 including the deletion of redundant requirements.

	43	Carry out engine ground run and check, as far as possible, all systems and services for correct operation. Check – power-plant installation for leaks following run. Ensure all cowlings, access panels and doors are secure.	X	X	X
	44	<del>Carry out Items 10 and 11 of the Check A when applicable to the type of aeroplane.</del>	X	X	X

\*Inspection Required shown X

(45) Glider Towing Hook Clean, Inspect, Test.

X X X